

AC/DC Track Circuit System OS and Fouling Circuit Applications

Style “C”, AC/DC Track Circuits address several problems that relate specifically to OS and Fouling Circuits. In addition, in these applications, the unique design and configuration of the AC/DC Track Circuit equipment supplied by Patco Industries, Inc. provide value-added enhancements to the user.

Problems experienced with OS and Fouling Circuits that are addressed by the AC/DC circuits include:

- A. Shunting sensitivity of AC/DC track circuits is superior to DC circuits, which can be especially helpful at lightly used industrial spurs and siding ends.
- B. For Fouling Circuits, the single-ended AC/DC track circuit eliminates a long cable run or an equipment housing at one end on the circuit (see figure 5).
- C. For OS Circuits, the key elements of the AC/DC track circuit (the AC/DC power feed, the track relay, and the diode) can be distributed in such a way as to allow direct shunting, as opposed to indirect or foul shunting, throughout the OS circuit (see figure 6). This configuration also provides a positive check of the fouling jumper wires. If the wires break, the track relay will de-energize, indicating occupancy.

Value-added enhancements provided by Patco equipment include:

- A. A single circuit Track Power Unit/AC Source Unit configuration reduces material costs over multiple circuit signal source.
- B. Where Fouling or OS Circuits are in close proximity, in AC Source Unit (Part# PAT-X-7913) can feed up to 6 Track Power Units (Part# PAT-X-7813)
- C. True square wave output of the AC Source Unit improves shunting sensitivity over sine-wave and modified square wave output devices.
- D. Use of AAR terminals throughout the AC/DC Track Circuit System equipment makes installation and maintenance easier.



E. Superior design Model# PAT-X-M10TD Track Diode offers:

1. Substantially greater surge resistance than that offered by any other brand diode.
2. Measurably improved signal levels to feed through bad track conditions, provide longer circuits and better shunting.
3. Heat sinking that reduces diode failures caused by high current flow during wet track conditions.
4. Waterproof construction.

Referencing the accompanying figure 5 (Fouling Circuit) and figure 6 (OS Circuit), the following notes apply:

1. Suggested "Rx" and "Rt" Values:

<u>Circuit Length</u>	0.50 Ω Relay		4.0 Ω Relay	
	<u>"Rx" Should Be</u>	<u>"Rt" Should Be</u>	<u>"Rx" Should Be</u>	<u>"Rt" Should Be</u>
500 Feet	1.5 Ω	5.0 Ω	6.0 Ω	28.0 Ω
1000 Feet	1.0 Ω	3.0 Ω	4.0 Ω	16.0 Ω

2. "Rx" is the Current Limiting Resistor. Value should never be lower than 1.0 Ω .
3. "Rt" is the Adjustment Resistor.
4. Both resistors may be adjustable, to achieve proper circuit operation. Again, "Rx" value should never be below 1.0 Ω .
5. In figure 5:
 - a. IJ1 should be located at the union between the curved stock rail and the curved main rail.
 - b. IJ2 should be located in the curved closure rail as close to the actual switch points as possible.



- c. IJ3 and IJ4 should be located no closer than the fouling point of the switch.
-
6. If the OS circuit you are planning to install will fall within the approach to a crossing warning system activated by a motion responsive or a constant warning time device, and you plan to have the crossing control equipment feed through the OS circuit, we recommend against using an AC/DC track circuit for the OS circuit.
 7. Choice of track relay is an important consideration. Common track relay coil values are 0.5, 2.0, and 4.0 ohms. The 0.5 ohm relay provides the greatest operating margins and the quickest shunting.
 8. It is desirable to keep track lead wire resistance to no more than 0.15 ohms (180 feet, total length both lead wires, using No. 9 AWG solid, copper wire). If the location of the shelter housing the relay(s) and the Track Power Unit(s) results in lead wire resistance greater than 0.15 ohms, separate wire pairs should be used for the relay and Track Power Unit; and limit and adjustment resistors should be reduced to compensate for the additional lead wire resistance.

Incomparatively short track circuits (1000 feet or less), higher track lead wire resistance can be tolerated. When configuring and adjusting such circuits, the lead wire resistance should be included in the total when determining the value of the adjusting resistor. To provide adequate adjustability, the lead resistance should be less than half the value chosen for the adjustment resistor.

9. Patco Industries, Inc. has available pre-wired panels suitable for backboard or 19" rack mounting, that include all components for one track circuit except the safety relay (see page 5). The Track Diode is included, but shipped separately. This handy package makes the job of circuit conversion or new circuit installation a very short process. The "Rx" and "Rt" values must be specified when ordering. The ordering reference info is; AC/DC Track Circuit Pre-Wired Panel (Part# PAT-X-71013).



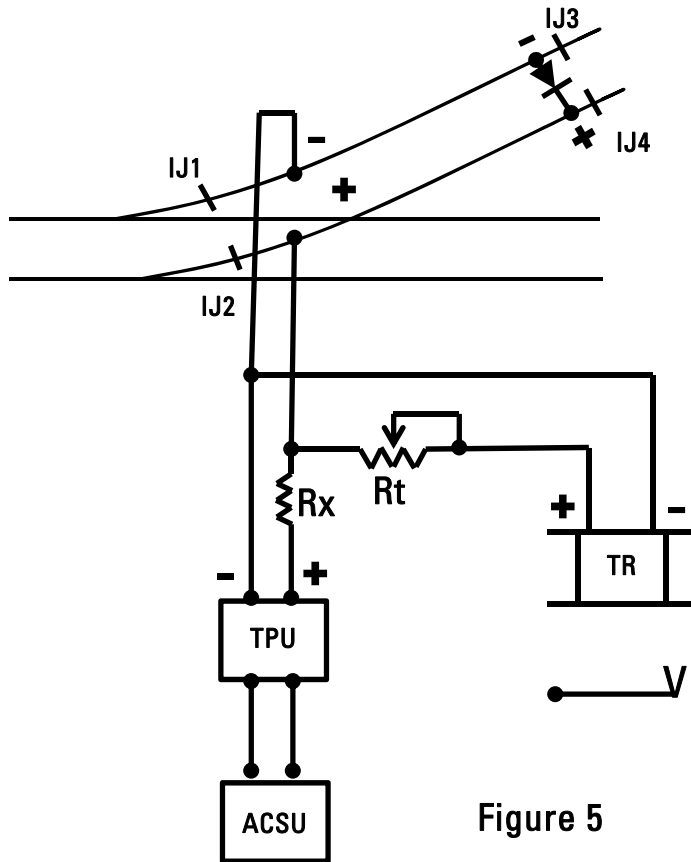

Figure 5

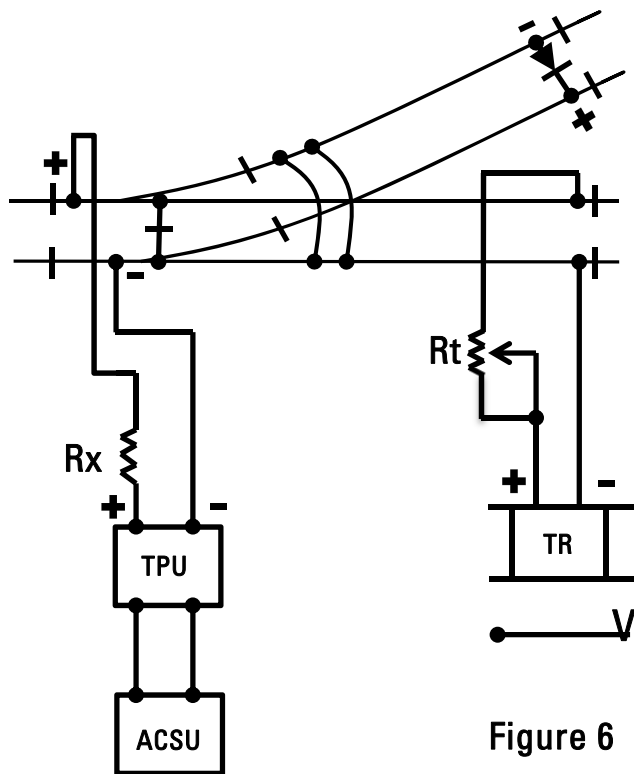

Figure 6

AC/DC Style "C" Track Circuit System

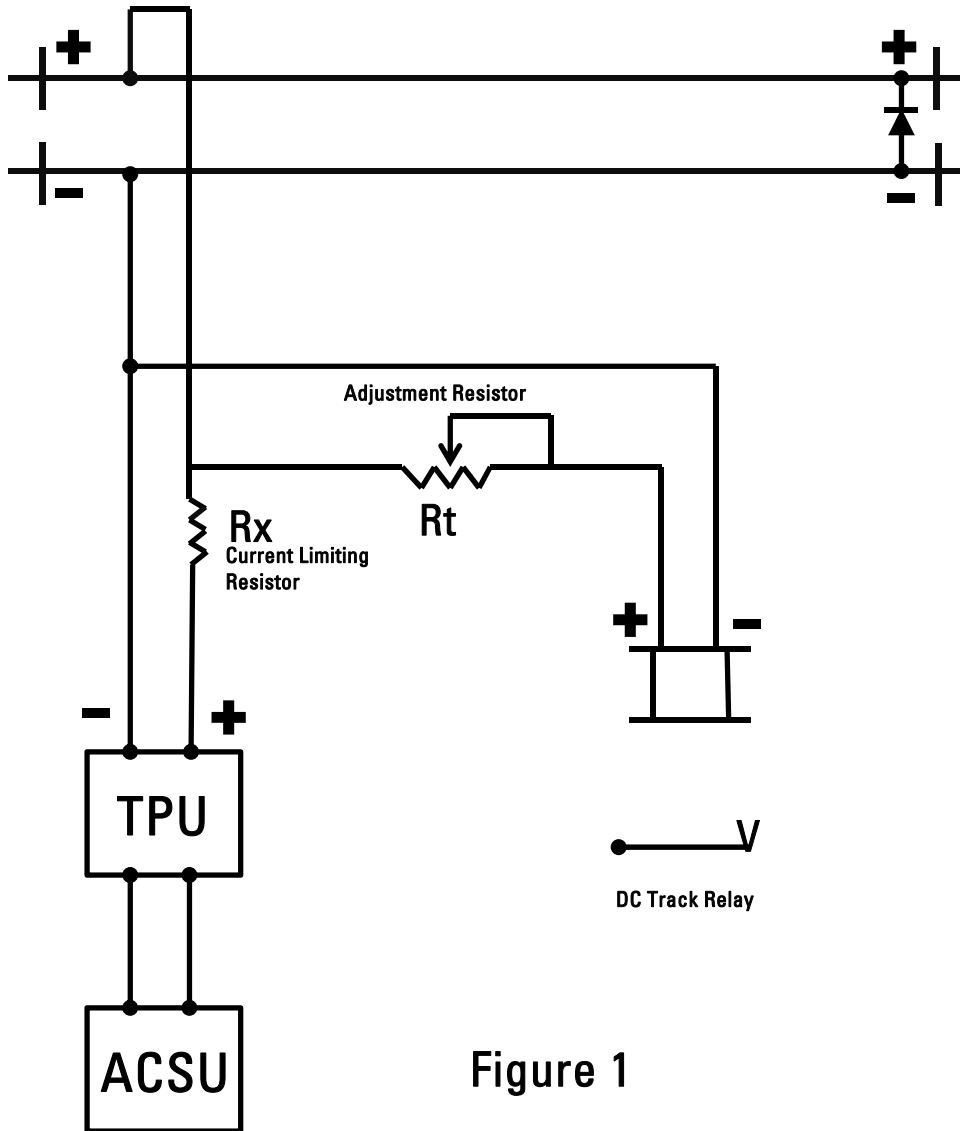

Figure 1

AC/DC Style "C" Track Circuit System



*AC Source Unit
Model PAT-X-7913*



*Model PAT-X-M10TD
Track Diode*



AC/DC Style "C" Track Circuit System



*Track Power Unit
Model PAT-X-7813*

*For sales assistance please contact
Patco Industries, Inc.
4830 52nd Avenue
Kenosha, WI 53144
(262) 658-3590
(262) 658-3593 – Fax
info@patcoindustries.com
www.patcoindustries.com/product-list*

